



800-767-6700 Sales@b-k.com

3196 Parts & Accessories

UniGuard/UniClear Machine Guards

- OSHA/ANSI compliant machine guarding solutions
- Build for employee safety/Easy installation
- CGU, ANSI, Direct Drive Coupling Guards and Belt Guards
- Shaft Seal Guarding (UniClear)



Mechanical Seals/Packing

Mechanical Seals



Piping Support Plans



Packing



Pressure Gauges

Great for monitoring pump system conditions. May be used to quickly troubleshoot or eliminate problems.

213.53-0/100#	WIKA 2.5 IN. GAUGE 0-100 PSI, 1/4 IN. NPT, LIQ FILL
213.53-0/15#	WIKA 2.5 IN. GAUGE 0-15 PSI, 1/4 IN. NPT, LIQ FILL
213.53-0/200#	WIKA 2.5 IN. GAUGE 0-200 PSI, 1/4 IN. NPT, LIQ FILL
213.53-0/200#-4	WIKA 4 IN. GAUGE 0-200 PSI, 1/4 IN. NPT, LIQ FILL
213.53-0/600#	WIKA 2.5 IN. GAUGE 0-600 PSI, 1/4 IN. NPT, LIQ FILL
213.53-0-160#	WIKA 2.5 IN GAUGE, 0-160PSI, 1/4IN NPT, LIQUID FILL
213.53-30FTH2O/+30FT	WIKA 2.5 IN. GAUGE -30FTH2O / 0 /+30FTH2O
213.53-30HG	WIKA 2.5 IN. GAUGE 30 IN. HG, 1/4 IN. NPT
213.53-30HG/30#	WIKA 2.5 IN. GAUGE 30 IN. HG / 30 PSI, 1/4 IN. NPT
215.53 -15-0/15	WIKA 2.5 IN. GAUGE -15PSI/0/+15 PSI
9767.061-0/100#	WIKA 2.5 IN. GAUGE 0-100 PSI, 1/4 IN. NPT
6K210	GAUGE GUARD - 1/4 IN. GAUGE/TRANSDUCER PROTECTOR - BUNA
6K216	GAUGE GUARD - BUNA



B&K Services

Service and Repair Operations based in Seattle—Vancouver—Spokane

- Impeller Balancing
- Impeller Trimming
- Laser Alignment
- Machining
- Field Service Installation/Removal
- PM and Troubleshooting
- Startup
- Complete Rebuilds



Pump Selection Guide

The Centrifugal Pump Selection Guide assists users in making an easy initial selection of the best pump for a particular service



iAlert System Monitoring/Predictive Maintenance

FEATURES AND BENEFITS:

- Monitor: 24/7 real-time pump monitoring
- Alarm: Takes high res data and stores it for later analysis
- Analyze: Diagnose machine faults with vibration tools Fast Fourier Transform (FFT) & Time Wave Form Analysis
- Environment: Rated for any industrial environment; water and dust resistant
- Wireless: Sync data via Bluetooth Smart enabled devices
- Online Monitoring: Manage all machines in one place



Controls

PumpSmart PS220

- Sensorless Flow Control
- Multipump Control
- Intelligent Sleep
- Cavitation Control
- Sensorless Pump Protection
- Smart Flow



PumpSmart PS20 Load Monitor

- Dry Run Protection



Manual



Power Ends

The 3196 power end fits 7 different process pumps to allow greater commonality of spares.



Shaft Replacement Kits

Reduce Repair Costs—Less expensive and time saving alternative to purchasing individual parts



Repair Kits

Kit includes elastomeric items, gaskets, bearing lockwasher, bearings, and lantern ring



Maintenance Kits

Kit includes elastomeric items, gaskets, and bearing lockwasher.



Complete Solution Kits

The efficient and effective way to maintenance & repair



Goulds model 3196 *i-FRAME*® Kits

www.gouldspumps.com

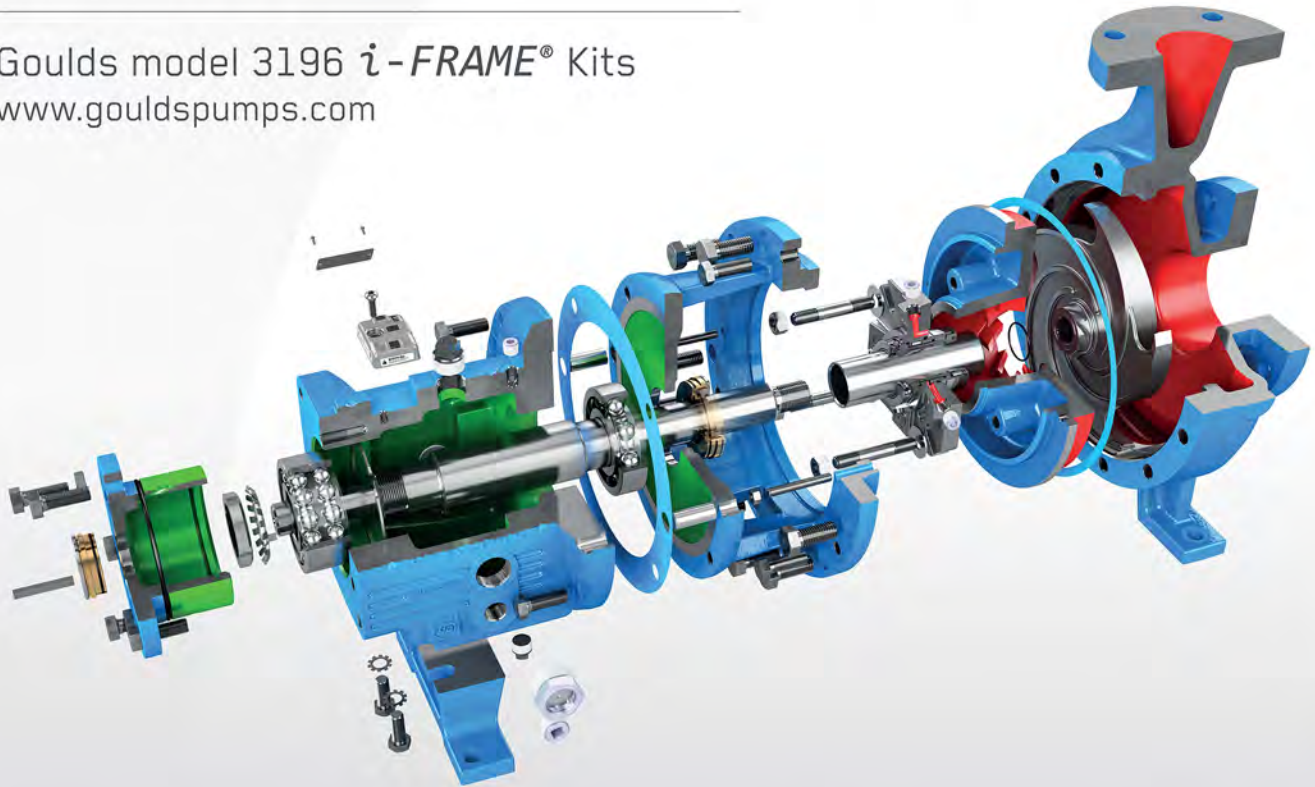

MAINTENANCE KIT

Item# 902

REPAIR KIT

Item# 906

SHAFT KIT

Item# 902D

POWER END KIT

Item# 920



Item#	Description
351	CASING GASKET
360D	GASKET - FRAME-TO-ADAPTER
382	BEARING LOCKWASHER
412A	O-RING, IMPELLER
496	O-RING, BEARING HOUSING
497F	O-RING, OUTBOARD LABYRINTH ROTOR
497G	O-RING, OUTBOARD LABYRINTH STATOR
497N	O-RING, INTERNAL (OUTBOARD)
497H	O-RING, INBOARD LABYRINTH ROTOR
497J	O-RING, INBOARD LABYRINTH STATOR
497L	O-RING, INTERNAL (INBOARD)

Item#	Description
105	LANTERN RING
112	OUTBOARD BEARING
136	BEARING LOCKNUT
168	RADIAL BEARING
351	CASING GASKET
360D	GASKET - FRAME-TO-ADAPTER
361A	RETAINING RING
382	BEARING LOCKWASHER
412A	O-RING, IMPELLER
496	O-RING, BEARING HOUSING
497F	O-RING, OUTBOARD LABYRINTH ROTOR
497G	O-RING, OUTBOARD LABYRINTH STATOR
497N	O-RING, INTERNAL (OUTBOARD)
497H	O-RING, INBOARD LABYRINTH ROTOR
497J	O-RING, INBOARD LABYRINTH STATOR
497L	O-RING, INTERNAL (INBOARD)

Item#	Description
112	OUTBOARD BEARING
122	SHAFT - WITH SLEEVE
126	SHAFT SLEEVE
134	BEARING HOUSING
136	BEARING LOCKNUT
168	RADIAL BEARING
332A	OUTBOARD LABYRINTH SEAL W/ O-RINGS
333A	INBOARD LABYRINTH SEAL W/ O-RINGS
357W	HEX NUT - COVER TO ADAPTER
361A	RETAINING RING
382	BEARING LOCKWASHER
400	COUPLING KEY
496	O-RING, BEARING HOUSING

Item#	Description
112	OUTBOARD BEARING
122	SHAFT - WITH SLEEVE
134	BEARING HOUSING
136	BEARING LOCKNUT
168	RADIAL BEARING
228A	BEARING FRAME
319	SIGHT WINDOW
332A	OUTBOARD LABYRINTH SEAL W/ O-RINGS
333A	INBOARD LABYRINTH SEAL W/ O-RINGS
357W	HEX NUT - COVER TO ADAPTER
361A	RETAINING RING
372T	BUTTON HEAD SCREW - I-ALERT#2
382	BEARING LOCKWASHER
408A	PLUG - OIL DRAIN, MAGNETIC
496	O-RING, BEARING HOUSING
761B	I-ALERT#2 CONDITION MONITOR



Emergency Service - 24 Hours a Day - 365 Days a Year

Seattle WA | Vancouver WA | Spokane WA | Palmer AK

Toll-Free: 800-767-6700

Fax: 206-767-6700